

Kappa Alpha Order

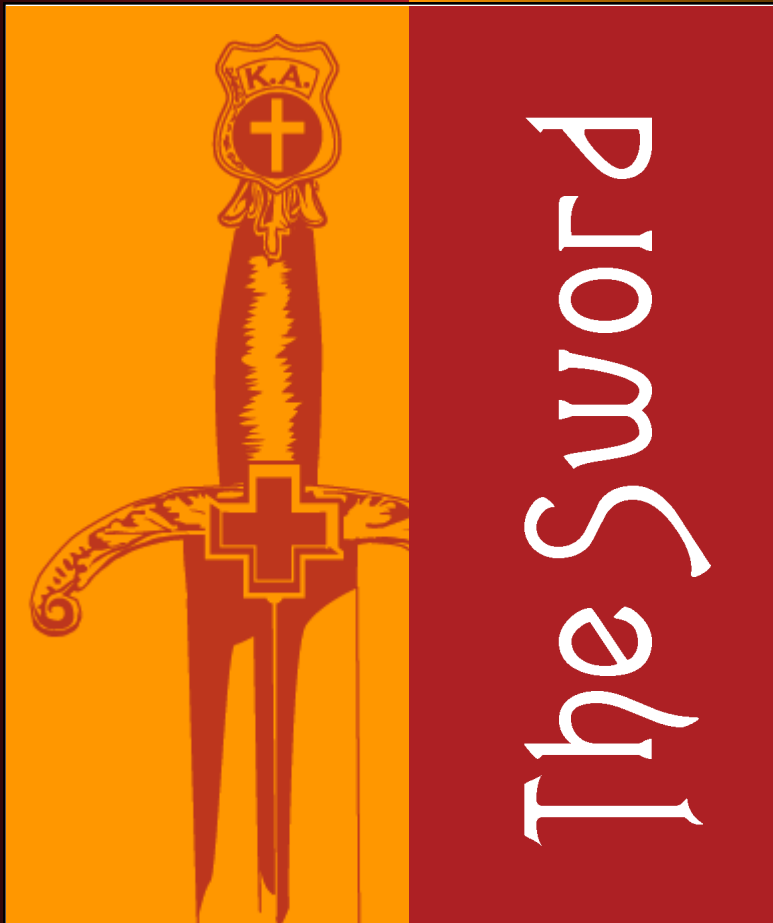

Excellence is our Aim

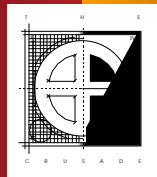

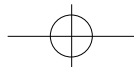
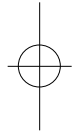
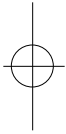
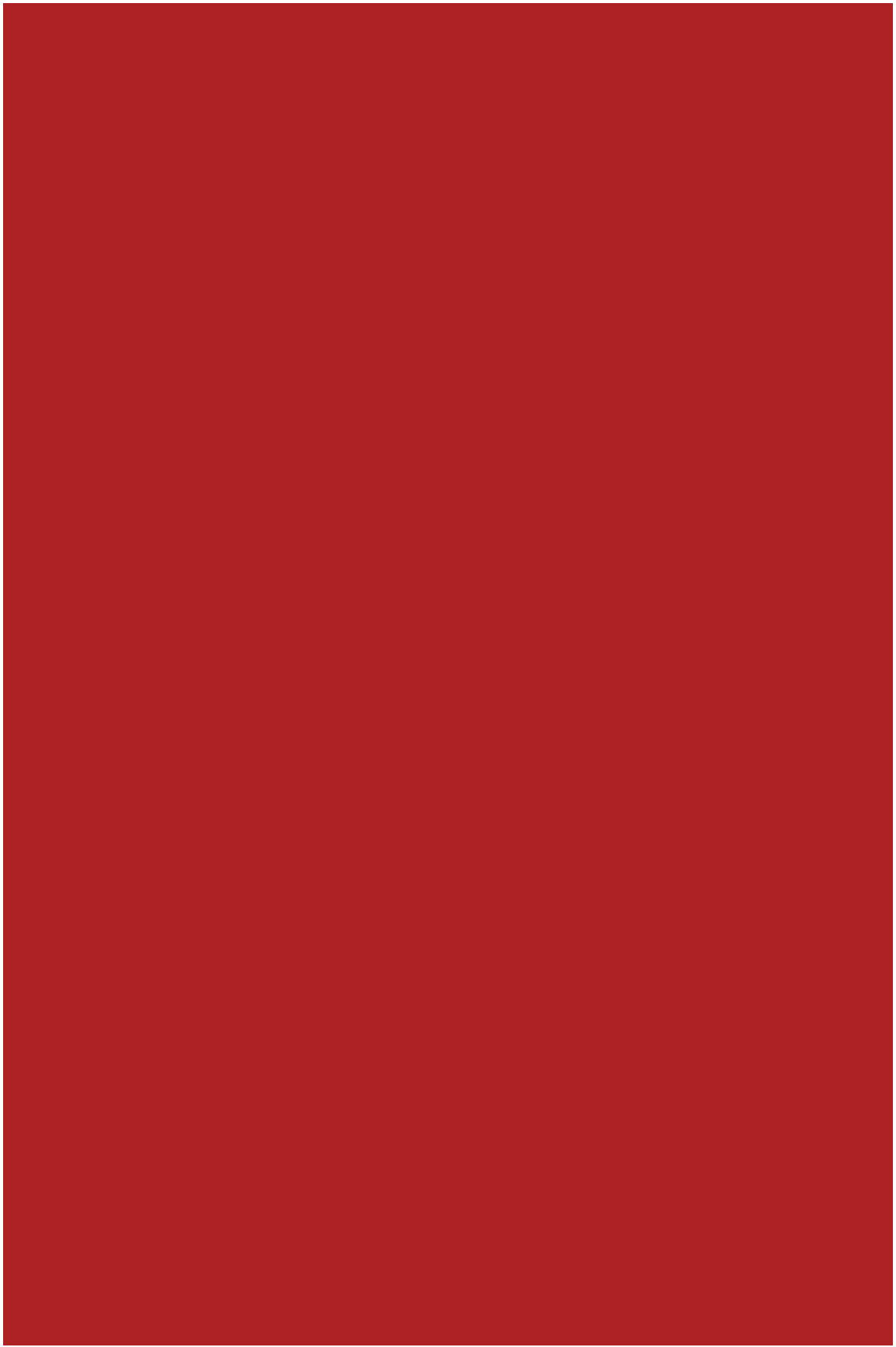

Kappa Alpha Order

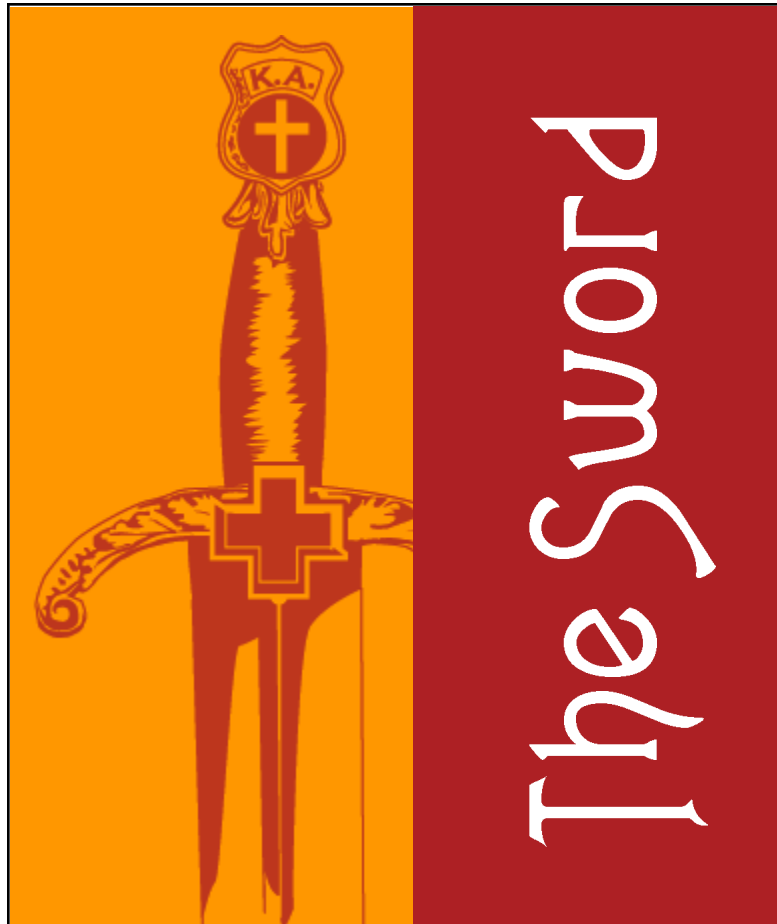

Excellence is our Aim

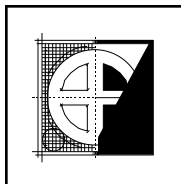



SIGNIFICANCE OF THE SWORD

The sword was the mark of the knight, one of his most prized possessions and a symbol of his high social and military standing. If, for some grave misdemeanor, a knight was stripped of his knighthood, his sword would be broken before his eyes. A sword, however, should not break. They were made to last a lifetime and often a sword was passed down from father to son, and each generation would add some design or jewel to the sword to make it his own.

Its cruciform shape, formed by the crosshilt or “quillons,” a transverse bar at the base of the hilt, also served as a potent religious symbol: in battle a fatally wounded knight would lift his sword before his eyes so that his last earthly sight would be the sign of the cross. Knights also incorporated relics into their swords, put religious inscriptions on the blade and often had their seals incorporated.

A sword was not complete without its scabbard. The most common scabbard, made by the sheather, was a wooden frame over which leather was stretched. More ceremonial swords had scabbards made of precious metals intricately designed and studded with jewels.

The sword was used for slashing rather than thrusting, and its shape changed little from the tenth to the fifteenth century. Its two-edged blade was roughly 32 inches long and two inches wide, tapering to a point. Such a blade weighed about 2 lbs. The blade had to be razor-sharp, capable of severing a thread floating in the air. Godfrey of Bouillon on the First Crusade was reputed to be able to cut off a camel's head with a single slash of his sword. Swords were sometimes imbued with mythic significance. Richard the Lionheart on his way to the Third Crusade gave to Tancred of Sicily, a sword which was believed to be the legendary Excalibur.

Knights, text by Deirdre Headon, illustrations by Julek Heller, Schocken Books, 1982

“Unto a Knight is given a sword, which resembles a cross in order to signify that Our Lord conquered on the cross, the death to which humanity was condemned for the sin of our first father, Adam. Similarly, a knight ought to destroy and utterly vanquish the enemies of the Cross by the sword; for chivalry exists to maintain justice. For that reason, the sword is made with two cutting edges, to signify that the knight ought to use it to uphold chivalry and justice.”

The Book of the Order of Chivalry, translated by Robert Adams from William Claxton's *The Book of the Ordre of Chyvalry*.

This Crusade of Excellence was undertaken by:

Name _____

Date _____

Chapter _____

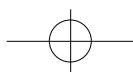



THE SEVEN PRINCIPLES

COMMITMENT

To education
To Kappa Alpha Order
To your brothers
To yourself
To excellence

ACADEMIC ACHIEVEMENT

Discipline to study
Appreciation of various fields of study
Goal setting
Hard work
Time management

RESPONSIBILITY

Personal
Teamwork
Accountability
Win-win outcomes
Interdependence and cohesiveness

DEVELOPMENT OF SELF

Mental fortitude
Spiritual reflection
Physical abilities
Leadership development
Pursuit of excellence

UNITY OF PURPOSE

Willingness to change
Knowing what you want and how to
get there
Goal setting
Learning from the challenges
Experiential learning

EXCELLENCE

Integrity, honesty, respect, truth and
fairness
Do the very best you can do
Superior quality
Investment of hard work and resources
Exemplifies the KA

SERVICE TO OTHERS

Service above self
Civic responsibility
Humility
Willingness to give
Daily actions





THE CRUSADE'S STATEMENT OF PURPOSE

Just as the knights of old struggled to free the Holy Lands, the knights of Kappa Alpha Order have embarked on The Crusade to restore credibility and worth of purpose to the fraternal experience. The purpose of The Crusade is to provide members with educational opportunities throughout their college experience. The emphasis placed on academic excellence, community service, teambuilding and leadership will be beneficial to the active participant not only during his college career, but also throughout life. Let us unite together as we aspire to achieve excellence through endeavor.

THE CRUSADE'S VISION STATEMENT

The Executive Council of Kappa Alpha Order has ratified the following as the vision statement for The Crusade. It reads as follows:

As Kappa Alpha Order prepares itself for the new millennium, it sees itself as the leader among fraternities. This lofty status demands the constant desire to maintain the highest ideals of gentlemanly conduct and achievement. Membership into Kappa Alpha Order strives to develop young men of moral fiber, leadership abilities and personal development skills along with a strong focus on academic excellence and service to others. Kappa Alpha Order encourages alumni involvement by creating means of interaction and assistance. It is through this involvement and interaction of both actives and alumni that The Crusade of Kappa Alpha Order is achieved.





SUMMARY OF THE PHASES OF THE CRUSADE

Voyage for Brotherhood

After receiving an invitation to join the Order, you, as a new member, go through the induction ceremony and begin The Crusade. This first phase, *Voyage for Brotherhood*, will emphasize the establishment of high standards in all areas relevant to your college career.

You will be given a planner each year to serve as a time management guide throughout The Crusade. *Brains, Books, and Brotherhood* will aid you in your crusade for academic achievement. Teambuilding activities will reinforce the responsibility and bond of brotherhood. Outside resources such as guest speakers and videos will be utilized. The value of service to others will be introduced through community service projects. This phase will last from six to ten weeks. Your formal initiation into the Kappa Alpha Order will mark the end of this phase.

Honor Bound

The second phase of The Crusade will focus on fostering an appreciation for values and ethics through in-depth study of the laws and customs of the Order. The value of Self Governance will be reinforced through group exercises, case studies, and guest speakers. Leadership within Kappa Alpha will be encouraged as members are required to hold an office or chair a committee and assist in coordinating a KA sponsored community service event.

Quest for Leadership

Developing your leadership skills will be of prime importance as the *Quest for Leadership* carries you into other campus organizations. As a crusader, you will be required to hold a leadership position in an outside university organization. Experiential learning will be emphasized through a weekend leadership retreat. Decision making skills will be addressed through the use of case study scenarios and survival simulations. Personal development will be emphasized through the presentation of educational modules. Outside speakers will address a variety of social issues. These may include alcohol, hazing, and STDs. A leadership style inventory test will be administered in order for you to pinpoint your exact leadership style. Service to the community will continue to be important as you help organize a project to benefit MDA.

The Journey Beyond

Phase IV will be designated as a time for crusade members to acquire the necessary tools for their crusade into the outside world. Attention will be given to career enhancing activities, service in the community, and the responsibility of KA membership after graduation. Businessmen will be brought in to address such topics as resume writing, interview skills, and dressing for success. You will have the opportunity to develop a resume and research a career of particular interest to you. Local alumni will address the importance of KA involvement after graduation. Service learning will be utilized by doing volunteer work within the community. This phase will last approximately one semester, and should be completed during the crusader's senior year.

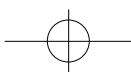

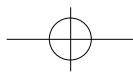
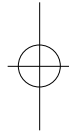
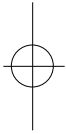

STANDARDS OF A CRUSADE CHAPTER MEMBER

Crusade Member

As a member awaiting initiation you are obligated by your association with this Crusade chapter to maintain certain individual standards as a member awaiting initiation and a Crusader. These include:

- Attend 80 percent of all Kappa Alpha Order functions
- Maintain a semester or quarterly GPA of at least 2.25
- Remain active in another campus organization
- Serve on a KA committee or hold a chapter office
- Meet all additional criteria for each phase of The Crusade

STANDARDS FOR A CRUSADE CHAPTER

As a Crusade chapter, your brothers have agreed to strive for a higher level of excellence. They have pledged to maintain these chapter standards:

- A commitment to the *Kappa Alpha Laws* and the customs of Order.
- A commitment to one of the pledge education programs established by the national organization or the approval of an alternative program submitted by the chapter.
- Remain devoid of hazing.
- Remain financially current with the National Administrative Office and have their budget filed with the National Administrative Office.
- Participate individually or jointly with one annual fund-raising event of the chapter's own choosing.
- Participate individually or jointly with one annual fund-raising event for MDA.
- Establish and maintain an alumnus advisory board consisting of a faculty advisor, chapter advisor, and a financial advisor.
- Establish and maintain a functioning Crusade committee whose duties will include being responsible for monitoring and enforcing the standards of the Crusade chapter.
- Maintain a chapter GPA that reflects academic excellence on your campus.
- Develop a code of conduct emphasizing reverence to God, duty, honor and character, gentlemanly conduct, and excellence.
- Present educational modules at chapter or phase meetings on issues such as social, ethics, values, diversity, honor, or duty.
- Hold at least one alumni function per semester or two per academic year.
- Send a semi-annual newsletter to all alumni.
- Sponsor one event for community/campus leaders each academic year.
- Participate in one event with another fraternity each academic year and one with a non-Greek campus organization (may include educational session, service project, or social event).
- Hold one experiential learning activity per semester or two per academic year.
- Participate in an annual non-alcoholic brotherhood retreat.
- Recognize a local church or religious organization for the use of their facilities.



BENEFITS OF A CRUSADE CHAPTER

- Crusade chapters are eligible for grant money for educational activities.
- Each member of a Crusade chapter will receive KA's professional time management planner by Franklin Covey, *The Gauntlet*.
- Crusade chapters will receive a library of books covering leadership, time management, academic success and various other topics.
- Crusade chapters will receive the first set of Crusade rush materials for free.
- A Crusade chapter will receive additional support from The National Administrative Office. The National Administrative Office will identify a Crusade consultant that will administer The Crusade program and serve as a liaison between the National Office and Crusade chapters. In addition, the Crusade consultant will visit the chapter annually to focus on leadership and teambuilding activities.
- A Crusade chapter will receive official Crusade chapter letterhead
- Crusade chapters will receive Crusade Accolade distinguishing them as a Crusade chapter.
- Crusade chapters will receive free alumni lists and labels upon request.
- Crusade chapters will be recognized in *The Kappa Alpha Journal*.
- Crusade chapters will be recognized at Convention.

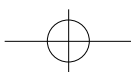
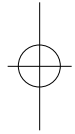
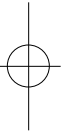



RESOURCES

Kappa Alpha Order is committed to ensuring that your chapter has the resources necessary to complete the requirements of the crusade program and to be successful on campus and an asset to your campus, the community, and our Order. Each crusade chapter receives a minimum of one visit per year from the headquarters staff and one from the commander of your province. Your primary resources should be the National Administrative Office, your alumnus advisor, and your commander.

National Administrative Office

There are 17 full-time staff people that work in Lexington, Virginia who are committed to seeing your chapter be successful. Please do not hesitate to contact the National Office if you have a question or need assistance. Your main contact will be the director of educational programming, your secondary contact will your consultant. Additionally, there are other chapter services staff who are able and willing to assist anytime you need them.

Commanders

Commanders serve in voluntary roles and they are charged with assisting and guiding their province's active and alumni chapters. He is the chief officer for the province and he is directly responsible to the Knight Commander. He is required to maintain contact with your chapter and he will be able to assist you on your crusade. The province commander is a valuable asset; he should be contacted any time there is a serious incident or problem.

Alumni Advisory Committee

This committee has been developed to oversee the day to day operations of your chapter. Your officers and chairmen should be meeting with these advisors on a regular basis. Remember that these are people who are extremely busy but have pledged themselves to helping you. Take the initiative to meet with them, ask questions, and take advantage of their expertise.

Greek Advisor

Your greek advisor is the most valuable resource on the campus. Please utilize this person as often as possible. Your greek advisor will have many resources in his/her office that will help you complete your Crusade requirements. These resources may include videos, educational materials, and access to other resources on campus.

Faculty Advisor

Your chapter is required to have a faculty advisor and this person has the potential to be a great resource. Take the time to meet this person as he/she can often help with academic situations and course scheduling.

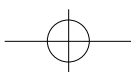

METHODS OF LEARNING

The Crusade program makes every effort to present interesting topics relating to your fraternal experience and personal development through a varied array of mediums. Some of these mediums are experiential learning, service learning, team-building, traditional methods of instruction and scenario-based learning.

Experiential Learning

Experiential learning is the idea of doing something for the sake of learning. It is a hands-on approach to learning that allows one to learn from experience rather than from a textbook.

Benefits of experiential learning to the participant include:

- Opportunity to interact with the world around you
- A broadened understanding of one's surroundings
- Enhancement of personal growth and self image
- Ability to work collaboratively with other people on real problems
- Possibility to improve citizenship, helping, learning, and occupational skills
- Ability to understand problems in a more complex way and to imagine alternative solutions
- Strengthened brotherhood by improving chapter communication, motivation, and cooperation.

Service Learning

Service learning is a method of experiential learning where participants learn and develop through active participation in thoughtfully organized service that is conducted in and meets the needs of the community. Individuals are connected in partnerships that provide opportunities for intensive and effective service to those in need and that create valuable learning environments. Service learning allows individuals to gain a better understanding of academic content by applying their skills and knowledge to benefit society. A keen awareness of one's self and one's environment is attained through the unique combination of service and learning. Other benefits of service learning are that it allows participants to explore careers and majors and form job links.

Teambuilding

Teambuilding has become an integral part of corporate America. Teambuilding is a form of experiential learning that focuses around a "team," or group of people unified by purpose, focused on a mission and committed to success. Successful

METHODS OF LEARNING

teambuilding adventures generally begin with a pre-program assessment of a group and team involvement in designing the curriculum. The process reveals if the foundations of teamwork are already in place and determines the program approach. A teambuilding activity may be any activity that focuses on professional relationships or improving organizational performance. Some examples may include a challenge or ropes course, and rock climbing.

Traditional Methods of Instruction

The Crusade employs many different types of educational instruction; one of these is traditional memorization, test taking and textbook oriented learning. During the *Journey for Brotherhood* phase, you may be required to take written tests on *The Varlet*. As you progress through the Honor Bound phase you will be required to memorize a passage from the customs of the Order and to pass a written exam on the *Kappa Alpha Laws*. These tests are not meant to be burdensome, they are simply the best way to teach and evaluate comprehension of the presented materials.

Scenario Based Learning

Throughout The Crusade you will be required to participate in discussion groups based on a scenario that has been presented to your group by the phase commander. These scenarios are designed to stimulate discussion and debate, in most cases there are several correct answers. The scenario discussion groups can take place anywhere you like, over dinner, in the house, away from the house, most importantly they should be conducted in a relaxed atmosphere where people can debate and have fun. They are not to be treated as assignments in school.

Peer Based Education

One of the most valuable ways to learn is from your peers. Peer based learning can be experienced in almost any form, but the true value is that it is from a respected peer. Often times it is difficult to grasp a concept that is being presented by an authority figure, however when the same idea is presented by a colleague it will appear more reasonable, and most importantly, understandable.



HOW TO USE *THE SWORD*

This handbook, *The Sword*, is designed to accompany you through your Kappa Alpha experience and your personal crusade of excellence. Its purpose is to facilitate the personal goal setting process and to provide you with a map. This map is designed to help you see where you have been and where you would like to go.

Documenting your progress will also help you understand how to apply the knowledge that you have recently experienced. Use this handbook to help you transform dreams into goals and goals into accomplishments.

Read, Think, Plan, Act, Review, & Document

Read - Read each section of the handbook as you enter the phase. Be sure that you understand the expectations that will be placed upon you. The information pages and other passages are there to provide guidance and inspiration.

Think - Think about setting your personal goals and the standards that have already been set for you. Are you capable of more? What do you want to accomplish? What are your motivators?

Plan - You have set your goals and now you are ready to proceed. First, you must develop a plan of action. Goals should be specific, measurable, action-oriented, realistic and timely. Be sure to tailor your action plan to meet all of the requirements set forth in your goals. Write down your plan in your handbook and note dates of accomplishments in your planner. Plan your work and work your plan.

Act - Get moving and don't wait to the last minute. You are the only person who can turn these dreams into accomplishments. Make it happen and don't be afraid to take charge!

Review - Constantly review your expectations and your action plans to ensure that you are still on course. After you have completed all of your goals take a minute and review the "To Think About" section of your handbook. These questions are to help you evaluate your experiences through the phase and hopefully you will be able offer suggestions to the younger brothers in the chapter.

Document - Document the completion of each goal in your handbook. This documentation process is designed to personally reinforce your accomplishments. Additionally, it sends a message to all the outside parties concerning your level of commitment.

Read, Think, Plan, Act, Review, & Document

At the end of your crusade you should aspire to be able to say that I have truly made a difference to my university, my fraternity and most importantly, myself.

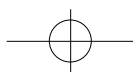

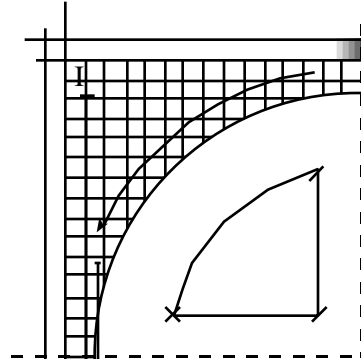

PHASE I

Voyage For Brotherhood

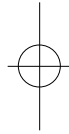
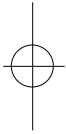

“The Kappa Alpha Order is something higher and better than a social club...,no secular order can have a better origin or a higher pupose”

W.M. Drake, Letter to the editor of *The Kappa Alpha Journal*, August 1895

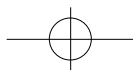

VOYAGE FOR BROTHERHOOD

SUMMARY

Your induction into Kappa Alpha Order marks the beginning of your crusade. *Voyage for Brotherhood* is the first phase in The Crusade. The purpose of this phase is to acquaint you with Kappa Alpha Order and its members through a carefully developed new member education program. Emphasis will also be placed on ensuring academic success by helping you establish high standards in all areas relevant to your college career. The following topics will be addressed:

Time Management	Etiquette	Responsibility of Brotherhood
Scholarship	Community Service	History of Kappa Alpha
Personal Finance		

During this phase you will be given a planner to serve as your time management guide. You should carry this planner with you to all new member meetings and use it on a daily basis. Teambuilding activities and community service projects will help to further unite you with the other members of your pledge class and will round out your *Voyage for Brotherhood*.

OBJECTIVE

To become acquainted with Kappa Alpha Order and its members

To become acclimated to the college environment

To establish high academic standards

To develop useful time management skills

To participate in community service

To learn proper etiquette for a multitude of occasions

EXPLANATION OF AN ORDER

The initiation of Samuel Zenas Ammen on October 17, 1866, began the first step in Kappa Alpha's change from a fraternity to an order. On occasion people will ask what makes KA an order, and not just another fraternity. According to Former Knight Commander Howard P. Locke, the difference is that, "A fraternity is a group of persons, who are associated together for some common purpose; the fulfillment together of mutual interest in time to come. An order is a society of persons who are associated together by possession of something previously acquired."

In our context, and in the historical sense of the word, orders have traditionally represented groups of individuals who were committed to the nobler pursuits of life. Kappa Alpha traces our roots to one of these orders, the legendary Knights Templar. The accomplishments of these creators of lofty ideals of character and defenders of right and innocence, have passed into the annals of history and have laid the framework for what has become the tenets of our Order. Their lives were great; their deeds were noble. Their object was to defend the right, protect the weak and guard the honor of women; and it is their purpose that has become ours.

Kappa Alpha is built of men who have taken oaths to uphold the noble tenets of our Order. As sworn brothers we must continue to look for men who have the "previously acquired" traits of honor, integrity, and duty. It is for these purposes that we exist.

The Kappa Alpha Journal, Fall 1994, "Explanation of an Order" -
D. Franta, G. Scott



VOYAGE FOR BROTHERHOOD

EXPECTATIONS

In order to complete the first phase of The Crusade, *Voyage for Brotherhood*, there are several expectations that you must fulfill. These have been broken down into expectations you must fulfill individually, within Kappa Alpha Order, and within your campus or community.

INDIVIDUAL

- Maintain a semester or quarterly GPA of at least 2.5.
- Prepare a personal budget.

KAPPA ALPHA ORDER

- Actively participate in your chapter's New Member Education Program and meet all requirements contained therein.
- Attend a non-alcoholic brotherhood-building retreat with other new members from your chapter.
- Join a chapter committee.
- Attend 80 percent of all chapter functions.

COMMUNITY

- Participate in a KA sponsored community service event.
- Join another campus organization.

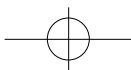



VOYAG E FOR BROTHERHOOD

Expectations

To help you successfully achieve the expectations of Phase I and your own personal goals you must first have a blueprint. The following pages are designed to help you create that “blueprint.” The first step in this process is to identify and jot down any personal goals that you may have. Secondly, record a realistic completion date. From this date backward plan and make notes of the specifics of how you plan to complete your objective. Additionally, note any major accomplishments or dates that need to happen in the notes section of your handbook.

REMEMBER - Goals are: Specific, Measurable, Action-Oriented, Realistic, and Timely

PERSONAL GOAL SETTING

Personal Goal 1:Goal: _____

Target Date for Completion: _____

Specific Actions: _____

_____**Personal Goal 2:**Goal: _____

Target Date for Completion: _____

Specific Actions: _____

_____**Personal Goal 3:**Goal: _____

Target Date for Completion: _____

Specific Actions: _____

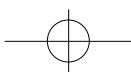
_____



VOYAG E FOR BROTHERHOOD

Individual Expectations

Expectation: Maintain a semester or quarterly GPA of at least 2.5

Personal Goal (if different from expectation): _____

Target Date for Completion: _____

Specific Actions: _____

Expectation: Prepare a personal budget

Personal Goal (if different from expectation): _____

Target Date for Completion: _____

Specific Actions: _____

“If a man does his best what else is there?”

George S. Patton





VOYAG E FOR BROTHERHOOD

Kappa Alpha Order Expectations

Expectation: Actively participate in your chapter's New Member Education Program and meet all the requirements contained therein.

Personal Goal (if different from expectation): _____

Target Date for Completion: _____

Specific Actions: _____

Expectation: Attend a non-alcoholic brotherhood building retreat with other new members from your chapter.

Personal Goal (if different from expectation): _____

Target Date for Completion: _____

Specific Actions: _____

Expectation: Join a chapter committee.

Personal Goal if (different from expectation): _____

Target Date for Completion: _____

Specific Actions: _____

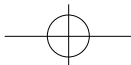



VOYAGE FOR BROTHERHOOD

Kappa Alpha Order Expectations

Expectation: Attend 80 percent of all functions

Personal Goal (if different from expectation): _____

Target Date for Completion: _____

Specific Actions: _____

*With a good conscience our only sure reward,
with history the final judge of our deeds, let us go
forth to lead the land we love asking His blessing
and His help, but knowing that here on earth
God's work must truly be our own.*

John F. Kennedy

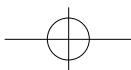
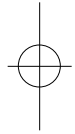
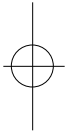



VOYAG E FOR BROTHERHOOD

Expectations within the Campus and Community

Expectation: Participate in a KA sponsored community service event

Personal Goal (if different from expectation): _____

Target Date for Completion: _____

Specific Actions: _____

Expectation: Join another campus organization

Personal Goal (if different from expectation): _____

Target Date for Completion: _____

Specific Actions: _____

Expectation: Attend one IFC or SGA meeting

Personal Goal (if different from expectation): _____

Target Date for Completion: _____

Specific Actions: _____

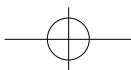



VOYAG E FOR BROTHERHOOD

What Kappa Alpha Offers

An important part of the philosophy of the Kappa Alpha Order is the conviction that men always ought to be more concerned with what they can give rather than with what they can receive, and yet a brother awaiting initiation has every right to ask about the contributions the Order will have upon his life. Kappa Alpha offers six.

First, membership in a well organized, well governed, financially sound, national society. The Knight Commander and the six Councilors are located throughout the country, and the administrative office, in historic Lexington, Virginia is at the heart of where our noble Order began. With over 130 active chapters, Kappa Alpha Order spans the entire country from the mid-atlantic to the great northwest.

Second, association with young men of the highest type. No man ever receives an invitation to join Kappa Alpha merely because he is a great athlete, an eloquent speaker or a gifted writer. This is not to say that the Order is indifferent to campus honors; it is deeply interested in them but it is far more deeply interested in the personality and character of the man who holds or seeks them. Our chapters, therefore, are made up of members who have undergone rigid scrutiny and who have been adjudged to possess the qualities of honor, duty, and reverence to God which the Order demands.

Third, an active and responsible social life. Within recent years American fraternities have been bitterly criticized for social excesses. Some of this criticism is justified. Kappa Alpha believes that its members need and have the right to an active social life, but it must be safe, responsible and governed by the Kappa Alpha Order Risk Management Policy.

Fourth, the privilege of being a brother of distinguished men. Kappa Alpha takes deep and solemn pride in its famous sons who have lifted high “the banner with the strange device” and who have displayed to the world living pictures of its ideals and principles.

Fifth, participation in a noble heritage of tradition. Kappa Alpha Order was founded on December 21, 1865, at Washington College, now Washington and Lee University, Lexington, Virginia. At that time the president of the college was Robert Edward Lee. Although he is not a member, his gracious and knightly beatitudes have been enshrined forever in our customs.

Sixth, the initiatory observances. In the past some fraternity initiations have been rather lurid and violent—involving various physical abuses and humiliations. There is no place for hazing in Kappa Alpha and all of our members are honor bound to stop and report any acts of hazing that they witness. Our initiatory observances are serious, impressive, and beautiful. Many good and wise men—notably Dr. Samuel Zenas Ammen—have contributed their best thought and zeal and affection to them, and the result is an unfailing fount of inspiration which has guided and strengthened generation after generation of those fortunate youths who have knelt at our altars.

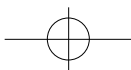

VOYAG E FOR BROTHERHOOD

What Kappa Alpha Of fers

Our tenets, principles and ideals are embodied in our ritual, thus creating a solid foundation on which noble character can be built. Kappa Alpha seeks to make a permanent contribution to our campuses and communities by inculcating in our members those gifts, graces and virtues that shone so brightly in the life of Robert Edward Lee. Many thousands of men in all stations of life can testify that they have been upheld in times of trial and temptation, comforted in sorrow, strengthened in adversity, and guided to the serene heights of achievement by the lessons they learned at Kappa Alpha's shrine.





VOYAGE FOR BROTHERHOOD

To Think About

Personal Goals Setting

Did I accomplish my personal goals? _____

Did I achieve my academic goals and potential? _____

New Member Program

Who was my New Member Educator? _____

What attributes do I admire in this person? _____

Which KA committee did I join? _____

How have I enjoyed getting to know the brothers and other new members?

Brotherhood Building Retreat

Where was the retreat held? _____

What were some of the activities I participated in during the retreat? _____

Which activities were my favorites? _____

What did I feel I gained during the retreat that will benefit me in my membership in Kappa Alpha Order? _____

Community

What outside campus organization did I join? _____

What have I gained from being a member of that group? _____

What has KA gained from me being a member of that group? _____

How have the skills I have acquired during my New Member Education Program helped me adjust to college? _____

Prepare a Personal Budget

Was I able to stay within the budget I prepared for myself? _____

What part of the budget worked? What parts did not work? _____





VOYAGE FOR BROTHERHOOD

Completed Expectations

Please check off each expectation as you fulfill it and complete the corresponding information. Once you have completed all expectations, please sign this form and show it to your phase commander. He will send notification to the National Administrative Office so that your completion of this phase may be noted.

INDIVIDUAL

- Maintain a semester or quarterly GPA of at least 2.5.
List your GPA from the most recent semester or quarter: _____
- Prepare a personal budget
Attach a copy of your budget:
- State the personal goals that you achieved: _____

KAPPA ALPHA ORDER

- Actively participate in your chapter's New Member Education Program and meet all requirements contained therein. _____
- Attend a non-alcoholic brotherhood-building retreat with other new members from your chapter.
List the date and location of your retreat: _____
- Join a chapter committee.
List the committee you serve on: _____
- Attend 80 percent of all chapter functions.

COMMUNITY

- Participate in a KA sponsored community service event.
List the community service event you participated in:
- Join another campus organization.
List the other campus organization you belong to: _____

I certify that the above information is accurate and complete.

Crusader's Signature

Phase Commander's Signature

Date

Date



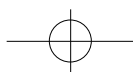
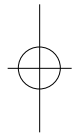
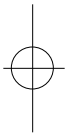

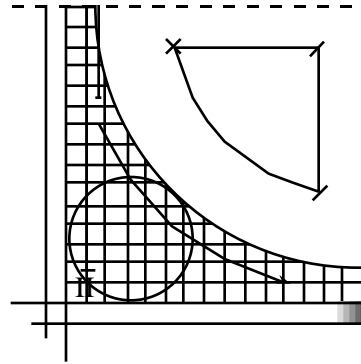

PHASE II

Honor
Bound

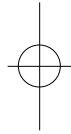
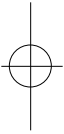

No person was ever honoured for what he received. Honour has been the reward for what he gave.

Calvin Coolidge

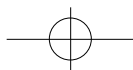

HONOR BOUND

SUMMARY

This second phase of The Crusade, *Honor Bound*, is intended to help you gain a better understanding of *Kappa Alpha Laws* and the customs of the Order as well as to foster in you a greater appreciation of values and ethics. The Council of Honor, a unique program of Kappa Alpha Order, will constitute the backbone of this phase. It will be used in conjunction with group exercises, case studies, and guest speakers to achieve our above-mentioned objectives. Your leadership skills will be enriched as you hold an office in KA or chair a committee and assist in coordinating a community service project.

OBJECTIVE

To gain a better understanding of *Kappa Alpha Laws*, customs of the Order and the initiation ceremony

To gain an appreciation of self governance, values and ethics

To develop leadership skills through leadership within Kappa Alpha

To enhance organizational skills through organizing a fund-raising event or community service event

To procure a working knowledge of parliamentary procedure

YOU ARE A KA

Sir, you are a Kappa Alpha. You are not just another fraternity man. You are a knight of the most unique organization among Greek letter societies. You have been familiar with a ritual and customs which emanated-not by accident, but by device-from the most noble qualities of the Knights of Old.

Into the heritage you have been presented are incorporated the highest ideals of fidelity to God and esteem of woman. You are KA. You can never be anything else and cannot do less than aspire to excellence. You cannot be petty, cowardly, unfair, unfaithful; you are a KA.

You have a serious challenge, indeed a direct obligation incumbent upon you as a KA. As you are the recipient of so rich a heritage, you are conscience-bound to be ever anxious to preserve, strengthen, and pass on the heritage to those brothers your Order chooses to entrust with it in the future.

You will never grow taller than when you stoop to help a brother. And you cannot desert him when others do. You can never become wiser by disregarding the sterling ideals of your Order. You can never worship your God more intimately than when you utilize the tools Kappa Alpha has given you.

And if you will do these things, you cannot but realized for yourself the respect of your fellow man, the wealth of mortal happiness, and the salvation by a generous God.

Roy Parsons, Alpha Kappa '46, University of Missouri



HONOR BOUND

EXPECTATIONS

In order to advance beyond this section of The Crusade, *Honor Bound*, you must complete the following list of expectations. These expectations have been divided into those that you must complete individually, within Kappa Alpha Order, and within your campus or community. These expectations must be met within this phase. They may not be completed prior to your admittance into this phase.

INDIVIDUAL

- Maintain a semester or quarterly GPA of at least 2.5.
- Complete one project related to the laws and customs of the Order
- Complete the self-evaluation - *Making Values Choices*
- Attend two presentations relevant to the laws and customs of the Order, or values and ethics.

KAPPA ALPHA ORDER

- Attend 80 percent of all chapter functions.
- Either successfully complete your chapter's Council of Honor Program or participate in two intensive workshops, one on the laws of Kappa Alpha and one on the customs of the Order.
- Assist in the review of your chapter's Code of Conduct.
- Hold an office, chair a committee or actively serve on a committee within KA.
- Participate in a minimum of two group exercises regarding values and ethics.

COMMUNITY

- Complete 33 hours of community service.
- Continue to be actively involved in at least one campus organization.
- Assist in the organization of one fund-raising event or community service event.

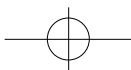



HONOR BOUND

Expectations, Objectives, Plans

To help you successfully achieve the expectations of this phase and your own personal goals you must first have a blueprint. The following pages are designed to help you create that blueprint. The first step in this process is to identify and write down any personal goals that you may have. Secondly, record a realistic completion date. From this date backward plan and make notes of the specifics of how you plan to complete your objective. Additionally, note any major accomplishments or dates that need to happen in the notes section of your handbook.

REMEMBER - Goals are: Specific, Measurable, Action-Oriented, Realistic, and Timely

PERSONAL GOAL SETTING

Personal Goal 1:
 Goal: _____

 Target Date for Completion: _____
 Specific Actions: _____

Personal Goal 2:
 Goal: _____

 Target Date for Completion: _____
 Specific Actions: _____

Personal Goal 3:
 Goal: _____

 Target Date for Completion: _____
 Specific Actions: _____

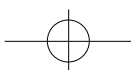



HONOR BOUND

Individual Expectations

Expectation: Maintain a semester or quarterly GPA of at least 2.5.

Personal Goal (if different from expectation): _____

Target Date for Completion: _____

Specific Actions: _____

Expectation: Complete one project related to the *Kappa Alpha Laws* and customs of the Order, or values and ethics.

Personal Goal (if different from expectation): _____

Target Date for Completion: _____

Specific Actions: _____

Expectation: Attend two presentations relevant to the *Kappa Alpha Laws* and customs of the Order, or values and ethics.

Personal Goal (if different from expectation): _____

Target Date for Completion: _____

Specific Actions: _____

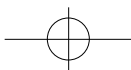



HONOR BOUND

Kappa Alpha Order Expectations

Expectation: Attend 80 percent of all chapter functions.

Personal Goal (if different from expectation): _____

Target Date for Completion: _____

Specific Actions: _____

Expectation: Complete your chapters Council of Honor or attend two intensive workshops, one on the *Kappa Alpha Laws* and one on the customs of the Order.

Personal Goal (if different from expectation): _____

Target Date for Completion: _____

Specific Actions: _____

Expectation: Assist in the review of your chapter's Code of Conduct.

Personal Goal (if different from expectation): _____

Target Date for Completion: _____

Specific Actions: _____

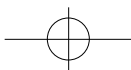



HONOR BOUND

Kappa Alpha Order Expectations

Expectation: Hold an office, chair a committee or actively serve on a committee within KA.

Personal Goal (if different from expectation): _____

Target Date for Completion: _____

Specific Actions: _____

It is better to deserve honours and not have them than to have them and not deserve them.

Mark Twain

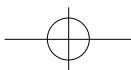
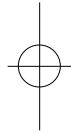
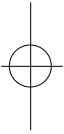



HONOR BOUND

Expectations within the Campus and Community

Expectation: Complete 33 hours of community service.

Personal Goal (if different from expectation): _____

Target Date for Completion: _____

Specific Actions: _____

Expectation: Continue to be actively involved in at least one campus organization.

Personal Goal (if different from expectation): _____

Target Date for Completion: _____

Specific Actions: _____

Expectation: Assist in the organization of one fundraising event or community service event.

Personal Goal (if different from expectation): _____

Target Date for Completion: _____

Specific Actions: _____

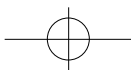



HONOR BOUND

COUNCIL OF HONOR

This second phase of The Crusade, *Honor Bound*, is intended to help you gain a better understanding of KA's laws and the customs of the Order as well as to foster in you a greater appreciation of values and ethics. The Council of Honor or the related workshops will serve as a backbone of this phase. Both options are designed to be used in conjunction with group exercises, case studies and guest speakers to achieve our above-mentioned objectives. Your leadership skills will be enriched as you hold an office in KA or chair a committee and assist in coordinating a community service project.

The Council of Honor is an intense study of the laws and customs of the Order. The Council, conceived at Gamma Chi Chapter (Texas Tech University), is one of Kappa Alpha's many unique contributions to the fraternity world. Its chief purpose is to provide KAs with greater insight into KA laws and our ritual.

There are a large number of reasons for a well-executed COH program:

- Better knowledge of KA's laws aids chapter officers in daily chapter operations, relations with the national office, and legal matters.
- Better understanding of *Kappa Alpha Laws* helps all chapter members make the laws "work" for them.
- Having experts on the laws prevents squabbles over procedure during touchy situations in chapter meetings.
- Successful implementation of parliamentary procedure will save time at meetings and guarantee that the minority is heard but the majority rules.
- Understanding of the Order's philosophical framework contributes to pledge education programming.
- Intense study of the ritual aids in interpretation and can make for a more meaningful performance of the customs of the Order.
- Appreciation of customs of the Order and its symbolism will provide a lifetime of enjoyment.
- The overall goal of the *Honor Bound* phase of The Crusade is to help each of us meet the obligation given to us in, *You are a KA*:

"You have a serious challenge, indeed a direct obligation incumbent upon you as a KA. As you are the recipient of so rich a heritage, you are conscience-bound to be ever-anxious to preserve, strengthen, and pass on the heritage to those brothers your Order chooses to entrust with it in the future."

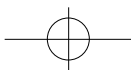



HONOR BOUND

Council of Honor

HONOR BOUND PROJECT S

There are many options to consider when deciding upon which project you want to undertake. Some projects can be done as a group (the COH class or Phase II) and some projects should be done individually. Below are some examples of Council of Honor projects:

Group Projects:

Hold a mock major offense trial– Have the phase group or COH class hold a mock major offense trial for the chapter. When done well this project will not only inform the chapter of the trial procedure, but it might spark discussion about by-laws, values, ethics and etc.

Conduct a model initiation–Have the COH class conduct a model initiation for the chapter. This would be an excellent opportunity for the chapter to come in contact with our ritual more than once or twice a year.

Instruct the new initiates on the secret work– Have the COH class instruct newly initiated members on the secret work. This could be done at a chapter meeting for the benefit of all members as well. This project could also include displaying the initiation regalia and an explanation symbols in our ritual.

Host a fundraiser to purchase new regalia– Have the phase group or COH class organize and host a fundraiser with the money used to purchase new regalia.

INDIVIDUAL PROJECTS:

Memorize a portion of our ritual – Present the passage to the chapter at a chapter meeting and share its importance to you and your life today.

Research the Crusades or Knighthood – Prepare a report that can either be given to the chapter, the phase group, or COH class. Place the report in the chapter archives.

Research Parliamentary Procedure / Robert's Rules of Order – Prepare a report that can either be given to the chapter, phase group or to the COH class. Place the report in the chapter archives.

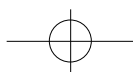



HONOR BOUND

Council of Honor

The Castle of the Joyous God

“Knights of the Kappa Alpha Order,—and I emphasize this word Knights because it means to me that there is a tremendous appeal in the ideal of Knighthood: It was said, you know, that when Cervantes wrote his Don Quixote that he left the idea of chivalry out of the book. But when we think of our tremendous fraternal organizations, when we think of the Masons, and the Knights Templar, the College Fraternities, and above all, of our own beloved Order, I think we will see that nothing can rob the ideal of knighthood and chivalry of its perennial appeal to the human heart. There is, as you know, some difference of opinion as to the designation of this word Knight. Some say that it means a youth, and in that sense it signifies the strength of youth, the fire, the enthusiasm, the high purpose of young manhood; and some think that it signifies a servant, a man who is pledged to go forth, to lift up the downtrodden, and to deliver the oppressed,—to stand up for the truth and the right. Now I think we can couple these three things together. To be a Knight is to be a fine, enthusiastic, and loyal servant, one pledged not to the service of himself, but to his cause, to the order to which he has pledged his life and loyalty. Now, of course, as you of Kappa Alpha so well know, this ideal chivalry came into its finest expression at the time of the Crusaders; and as we know, no page of the world’s history has been nobler, and no age has bred nobler spirits. Let the name go on. “Though his body be as the burnished flame, and his sword as keen as the forked lightning, yet will I stand my ground!” So cried Sir Herbert B. Tree, the great knight. So cried for all his brothers, Sir Carrel Bouillie, Richard, the Lionheart, and the rest. Well, those days of chivalry have passed away, and those knightly souls have gone to their repose. In those words, so familiar to us—“Their arms are dust, their swords are rust; their souls are with the saints, we trust; but their ideal lives on!”—we find a statement of our own sentiment. And in less picturesque surroundings, we modern knights carry on their work. Just as the Knights of the Crusades stood pledged to the highest things of their day, so we stand pledged to chivalrous things, to loyalty, to friendship, to mastery over self, to unselfish service toward our brothers.

Now, I think if a man is going, to try to live up to that, he needs to have an ideal in his life,—some person, or saint, or cause,—to which he strives to be loyal. When King Arthur and his Knights of the Round Table ruled in Britain, the fairest of their castles was called The Castle of the Joyous God. Sir Lancelot went there in the days of his strength and purity, when he was an unselfish knight and a stainless gentleman; and from that castle would go out to fight against the heathen and the enemy of his country. And then he would return again when his victories were won, to rest from his battles, and to gain strength for future conflicts. Well, the

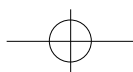



HONOR BOUND

Council of Honor

years have gone. Sir Lancelot fell in the ways of idleness, and finally pleasure and self-indulgence, stronger than the heathen, overcame him. He came no more to The Castle of the Joyous God. He went his way to sing his guilty song with Guinevere, King Arthur's Queen, and The Castle of the Joyous God stood upon its height desolate and forlorn; and men changed its name to The Castle of the Dolorous God. No more the place where a strong man came to renew his strength and an abode of joyousness, but the scene of a lost soul, and an abode of sorrow! Now I think that men are like Sir Lancelot. We need some citadel in our life where we have, untarnished, a high ideal, and where we can retire from time to time to renew our strength when the temptation to do something that is little and mean and dishonorable comes about us, and would pull us down from our better and higher selves. If you have ever seen a ship returned from a voyage in the warm waters of some southern sea, you have seen the barnacles of the sea weed that attached themselves to it. Well, she must go into dry dock, be cleansed of those, before the next voyage. So sometimes a man, in his voyage through the waters of life, must come into mental and spiritual dry docks, to have the unworthy things that cluster about him taken off, so that he can make a fair voyage to a safe haven. And just as the ship's compass needs, from time to time, to be adjusted, so does a man's conscience need, from time to time, to be corrected from misleading influences pointing away from the Door of Truth And so I say that every man needs an ideal in his life. And what I ask you to-night is to make your ideal Kappa Alpha,—the vows you have taken to her service, the memory of that night when you knelt at her altar, and prayed that you might be worthy of the tremendous gifts of happiness and friendship and loyalty that you have brought into your life! We need an ideal, and I know of no finer ideals that we could have than this noble Order to which you and I consider it a privilege to belong.”

Former Knight Commander H.J.Mikell, Alpha Alpha
December 29, 1923 - 32nd Convention

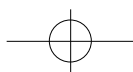



HONOR BOUND

To Think About

Ritual

Why is Kappa Alpha Order's ritual so special? _____

How can I incorporate the ritual into my daily life? _____

Code of Conduct

Why is it so important that my chapter have a Code of Conduct? _____

What are the most important aspects of my chapter's Code of Conduct? _____

Leadership within KA

What office do I hold in KA or what committee do I serve on? _____

What have I learned in this position that will help me in future endeavors? _____

Values

Why are values and ethics important in leadership? _____

What will I do to more fully apply my values to the decisions I make? _____

Community Service Project

What was the project? _____

What was my most memorable experience about working with another chapter member? _____



HONOR BOUND**Completed Expectations**

Please check off each expectation as you fulfill it and complete the corresponding information. Once you have completed all expectations, please sign this form and give it to your phase commander. He will send notification to the National Administrative Office so that your completion of this phase may be duly noted.

INDIVIDUAL

- Maintain a semester or quarterly GPA of at least 2.5.
List your GPA from the most recent semester or quarter: _____
- Complete one project related to Council of Honor.
Please list the project you completed: _____
- Complete the self-evaluation, "*Making Values Choices*"
- Attend two presentations relevant to the Council of Honor or values and ethics.
Name of presenter, date, and topic: _____
Name of presenter, date, and topic: _____

KAPPA ALPHA ORDER

- Attend 80 percent of all chapter functions.
- Successfully completed your chapter's Council of Honor Program.
OR participated in BOTH the *Kappa Alpha Laws* and customs of the Order workshops.
- Assist in the review of your chapter's Code of Conduct.
What changes were made to the Code of Conduct? _____

- Participate in a minimum of two group exercises regarding values and ethics.
Name the two group exercises that you participated in: _____



HONOR BOUND

Completed Expectations

COMMUNITY

- Complete 33 hours of community service.
State how you completed your 33 hours of community service.

- Continue to be actively involved in at least one other campus organization.
List the campus organization you belong to: _____
- Assist in the organization of one fundraising event or one community service event.
List the event you helped to organize: _____

I certify that the above information is accurate and complete.

Crusader's Signature

Phase Commander's Signature

Date

Date





PHASE III



Quest For
Leadership

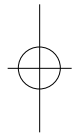
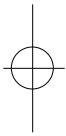

Be a hero in the strife.

Longfellow

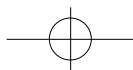

THE QUEST FOR LEADERSHIP

SUMMARY

You are now ready to embark on the third phase of The Crusade, *The Quest for Leadership*. The Quest for Leadership seeks to help you develop leadership skills that will prove essential to you throughout your life. These fundamental skills will benefit you not only in college, but as you enter into your chosen profession. The completion of a leadership style self-assessment will help you pinpoint your leadership style. This leadership style will be developed as you take part in a leadership role in another university organization. Additionally you will be enriched as you participate in a weekend long leadership retreat, and lead your chapter in developing a project for the benefit of Muscular Dystrophy Association.

OBJECTIVE

To pinpoint your leadership style

To develop your leadership skills

To expand your leadership beyond Kappa Alpha Order, into your college campus

To appreciate the various types of leadership

To increase your knowledge of campus government

To develop an awareness of social issues affecting you and your brothers

LEADERSHIP

Leadership is the art of influencing human behavior and the ability to properly handle people. A leader is someone who possesses qualities necessary to direct others. Robert E. Lee has been recognized by historians and countless others as a great leader. He was ambitious and possessed a bright and polished image. He has been further described as an "individual who embodied all that is decent and honorable in a society that is blessed by God." Lee's style of leadership's best been described in his own words, "I think and work with all my power to bring the troops to the right place at the right time; then I have done my duty. As soon as I order them into battle, I leave my army in the hands of God." Robert E. Lee commanded his men through respect and admiration rather than through fear.

There are countless examples of Lee's leadership on the battlefield and in civilian life. Just as you may be called on by your brothers and classmates to be a leader in your chapter, on your campus, or in your community, Lee was often called on to be a leader in his community. After the war, when Lee was in Lexington, there are many instances when he would squelch altercations between local residents and pro-union citizens. With tensions high, he would personally ride Traveler out to settle the disputes. By taking this action, he was not saying that he agreed with the war's outcome, but instead, he was exhibiting the type of leadership that made him an icon for the ages. Lee knew that mankind must progress and move forward, he bore malice towards none. His example was one of peace and reconciliation.

QUEST FOR LEADERSHIP

EXPECTATIONS

In order for you to fully reach your leadership potential during the *Quest for Leadership*, certain expectations have been outlined for your completion. These expectations include items that must be completed individually, within Kappa Alpha Order and within your campus or community. These expectations must be met within this phase. They may not be completed prior to your admittance into this phase.

INDIVIDUAL

- Set goals pertaining to personal finances, physical fitness, etc...and document those in your planner.
- Maintain a semester or quarterly GPA of at least 2.5.
- Set a personal academic goal and document it in the planner. (Record of achievement section)
- Complete a leadership style self-assessment (Human Synergistics LSI, Myers-Briggs, etc...).
- Address a relevant social issue within your phase group.
- Attend at least one presentation on leadership or social issues by a guest speaker on campus.
- Read one book on leadership.

KAPPA ALPHA ORDER

- Attend 80 percent of all chapter functions.
- Assist in organizing one project benefiting MDA.
- Assist in the organization of one experiential learning activity for your chapter.
- Continue to hold a leadership position within KA (Committee member, committee chair, officer).
- Participate in at least three scenario based learning discussions during your quest for leadership.
- Present a short synopsis of your leadership book to your phase group.
- Attend province council if you have not previously done so.

COMMUNITY

- Complete 33 hours of community service before the end of phase III.
- Participate in a weekend long leadership retreat or leadership institute (Examples include SEIFC, UIFI, and other state or school sponsored leadership schools. Contact the national office or see your Greek advisor for further suggestions.)
- Hold leadership role in university organization, outside of KA.
- Attend one IFC or SGA meeting.



QUEST FOR LEADERSHIP

Expectations, Objectives, Plans

To help you successfully achieve the expectations of Phase III and your own personal goals you must first have a blueprint. The following pages are designed to help you create that “blueprint.” The first step in this process is to identify and jot down any personal goals that you may have. Secondly, record a realistic completion date. From this date backward plan and make notes of the specifics of how you plan to complete your objective. Additionally, note any major accomplishments or dates that need to happen in the notes section of your handbook.

REMEMBER - Goals are: Specific, Measurable, Action-Oriented, Realistic, and Timely

PERSONAL GOAL SETTING

Personal Goal 1:

Goal: _____

Target Date for Completion: _____

Specific Actions: _____

Personal Goal 2:

Goal: _____

Target Date for Completion: _____

Specific Actions: _____

Personal Goal 3:

Goal: _____

Target Date for Completion: _____

Specific Actions: _____

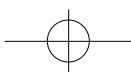



QUEST FOR LEADERSHIP

Individual Expectations

Expectation: Maintain a semester or quarterly GPA of at least a 2.5 GPA.

Personal Goal (if different from expectation): _____

Target Date for Completion: _____

Specific Actions: _____

Expectation: Set a personal academic goal and document it in *The Gauntlet*. (Record of achievement section)

Personal Goal (if different from expectation): _____

Target Date for Completion: _____

Specific Actions: _____

Expectation: Complete a leadership self-assessment.

Personal Goal (if different from expectation): _____

Target Date for Completion: _____

Specific Actions: _____

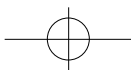



QUEST FOR LEADERSHIP
Individual Expectations

Expectation: Address a relevant social issue within your phase group.

Personal Goal (if different from expectation): _____

Target Date for Completion: _____

Specific Actions: _____

Expectation: Attend at least one presentation on leadership or social issues by a guest speaker.

Personal Goal (if different from expectation): _____

Target Date for Completion: _____

Specific Actions: _____

Expectation: Read one book on leadership.

Personal Goal (if different from expectation): _____

Target Date for Completion: _____

Specific Actions: _____

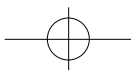



QUEST FOR LEADERSHIP

Kappa Alpha Order Expectations

Expectation: Attend 80 percent of all chapter functions

Personal Goal (if different from expectation): _____

Target Date for Completion: _____

Specific Actions: _____

Expectation: Assist in the organization of one project
benefitting MDA.

Personal Goal (if different from expectation): _____

Target Date for Completion: _____

Specific Actions: _____

Expectation: Assist in the organization of one experiential
learning activity

Personal Goal (if different from expectation): _____

Target Date for Completion: _____

Specific Actions: _____

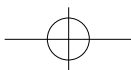



QUEST FOR LEADERSHIP

Kappa Alpha Order Expectations

Expectation: Continue to hold a leadership role in Kappa Alpha

Personal Goal (if different from expectation): _____

Target Date for Completion: _____

Specific Actions: _____

Expectation: Participate in at least three scenario based learning discussions within your phase group.

Personal Goal (if different from expectation): _____

Target Date for Completion: _____

Specific Actions: _____

Expectation: Present a short synopsis of the leadership book you read to your phase group.

Personal Goal (if different from expectation): _____

Target Date for Completion: _____

Specific Actions: _____

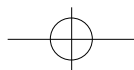



QUEST FOR LEADERSHIP

■ WHAT IS A LEADER?

Simply and plainly defined, a leader is a man who has followers.

The leader is a great servant. The Master of Men expressed the ideal of leadership in democracy when he said, "And whosoever be chief among you let him be your servant."

The leader sees things through the eyes of his followers. He puts himself in their shoes and helps them make their dreams come true.

The leader does not say, "Get going," instead he says, "let's go" and leads the way. He does not walk behind with a whip; he is out in the front with a banner.

The leader assures that his followers are working with him, not for him. He considers them partners in the work and sees to it that they share in the rewards. He glorifies the team spirit.

The leader duplicates himself in others. He is a man builder. He helps those under him to grow big because he realizes that the more big men an organization has the stronger it will be.

The leader does not hold people down. He lifts them up. He reaches out his hand to help his followers scale the peaks.

The leader has faith in people. He believes in them, trusts them, and thus draws out the best in them. He has found that they rise to high expectations.

The leader uses his heart, as well as his head. After he has looked at the facts with his head, he lets his heart take a look too. He is not only a boss—he is also a friend.

The leader is a self-starter. He creates plans and sets them in motion. He is both a man of thought and a man of action—both dreamer and doer.

The leader has a sense of humor. He is not a stuffed shirt. He can laugh at himself. He has a humble spirit.

The leader can be led. He is not interested in having his own way, but in finding the best way. He has an open mind.

The leader keeps his eyes on high goals. He strives to make the efforts of his followers and himself contribute to the enrichment of personality, the achievement of more abundant living for all, and the improvement of civilization.

-Wilford A. Peterson

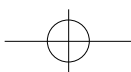



QUEST FOR LEADERSHIP

Expectations within the Campus and Community

Expectation: Complete 33 hours of community service before completing Phase 3

Personal Goal (if different from expectation): _____

Target Date for Completion: _____

Specific Actions: _____

Expectation: Participate in a weekend long leadership retreat or leadership institute

Personal Goal (if different from expectation): _____

Target Date for Completion: _____

Specific Actions: _____

Expectation: Hold a leadership role in another university organization

Personal Goal (if different from expectation): _____

Target Date for Completion: _____

Specific Actions: _____

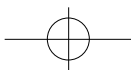



QUEST FOR LEADERSHIP

Expectations within the Campus and community

Expectation: Attend one IFC or SGA meeting

Personal Goal (if different from expectation): _____

Target Date for Completion: _____

Specific Actions: _____

Leadership is the courage to admit mistakes, the vision to welcome change, the enthusiasm to motivate others, and the confidence to stay out of step when everyone else is marching to the wrong tune.

E.M. Estes, former president
of General Motors





LEE'S LESSONS ON LEADERSHIP

Accept life as it is and make the best of it. "Live in the world you inhabit. Look upon things as they are. Take them as you find them. Make the best of them. Turn them to your advantage."

To lead others, one must first master oneself. "I cannot consent to place in the control of others one who cannot control himself."

A leader's primary responsibility is to think of others first. The "great duty of life" is "the promotion of the happiness and welfare of our fellow men."

Do your own reconnaissance. A leader uses his own eyes and ears to investigate facts whenever possible. One true mark of a leader is the courage to pursue information to its logical conclusion and to have the cool-headed, clear-eyed good judgement not to mistake sheep for soldiers.

Leadership is legitimized by success under fire. To be a leader, one cannot wait on the sidelines. One has to take responsibility, enter the fray, and prove that one has the resourcefulness, ability, and character to get things done.

Leadership requires moral responsibility. A leader is responsible not only for his own actions but for those of his subordinates and for the overall effect of his enterprise.

An effective leader is an effective administrator. Finish the day's work in the day allotted, maintain an orderly camp (or more likely, office), and while sharing "the hard task and the common fare" of one's subordinates and adding on top of it the responsibilities of paperwork and supervision, make time for rest, recreation, and reflection. This is not time wasted, but time restored.

A leader knows that "men's passions forge their fetters." A leader controls his passions and his appetites; they do not control him.

A leader is free to act so far as he is free from debt. A leader keeps his objectives consistent with his means.

A good leader is first a good subordinate. Leadership must be earned.

A leader must be decisive - his decisions a fulfillment of his duty, vision, and experience. "Lee was a thorough man of business, quick to decision, yet methodical in all he did. He knew what he wanted. He knew what an army should be."

A good leader is humble. He guards against ego distorting his vision. A leader has to achieve his army's or his business' or his team's goals, not his private ones. A leader's role is one of service.

A leader focuses his subordinates on their common goal and inspires them by his own devotion to achieving it.

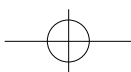

LEE'S LESSONS ON LEADERSHIP

A leader orders hard work and enforces necessary discipline but doesn't suffocate his subordinates' initiative or spirit. His goal is assembling a "voluntary association of gentlemen organized for the sole business" of his enterprise.

A leader has the integrity to face facts - and the courage not to be intimidated by them.

A leader is strategically and tactically aggressive: make the most of opportunities, constantly advance toward your objective. "We cannot afford to be idle."

A leader keeps his people focused on their common objective; morale is the product of a leader's vision and example.

A leader knows that if he is generous with his time, his people will be generous with their efforts.

A leader's one unalterable rule: assess circumstance and make the best of them.

A leader consults his subordinates. Talk through alternative approaches and explain your views. It is the best teaching tool you have.

Learn to delegate. Find your Stonewall (find subordinate officers you trust and who share your vision, and turn them loose).

The best motivator - as with Stonewall Jackson - is to grant your officers independence and responsibility.

People matter, individuals matter; no system, however well-oiled, and no leader, however omniscient, can afford to ignore the importance of personnel and having the right people in the right posts.

A leader takes full responsibility for the failures on his watch, and never tries to shift blame to his subordinates. A leader's job is not to assign blame but to make the best of every circumstance and to meet every new challenge to his objective.

A leader who earns the respect of his adversary can save himself battles.

A leader should always conduct himself so that he might enjoy the "satisfaction that proceeds from the consciousness of duty faithfully performed."

A leader must keep hope alive when his people must work - even suffer - under the most adverse conditions, and continue to seek every opportunity for victory.

A leader remembers that the goal of leadership is not self-fulfillment but service to his fellow men.

The true measure of a leader is how well he matches effective fulfillment of his duty with the forbearing use of force.

Harry Crocker - *Robert E. Lee on Leadership*



QUEST FOR LEADERSHIP

To Think About

Personal Goals Setting

Did I accomplish my personal goals? _____

Did I achieve my academic goals and potential? _____

Leadership Style Self-Assessment

What did I learn about my leadership style? _____

How can I use this style to my advantage when leading others? _____

Experiential Learning Activities & Scenario Discussions

What was the activity? _____

What part did I play? _____

Were you in agreement with your peers? _____

Was there more than one way to achieve your end? _____

Leadership in Campus Organization

Which organization did I hold a leadership position in? _____

What was my role? _____

In this organization, where do I need to take initiative and exercise personal leadership to strengthen the organization? _____

How will I do that? _____

Leadership Reading

What did I learn from the book I read? _____

How can I apply what I learned to everyday life? _____

Leadership Retreat

Who sponsored the retreat? _____

Where was it held? _____

What was my favorite part of the weekend? _____

What did I learn that will most help me in other leadership positions? _____

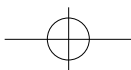

QUEST FOR LEADERSHIP

To Think About

MDA Project

What was the project? _____

How did it benefit MDA? _____

How can we improve the project in the future _____

Community Service

Where did I complete my community service? _____

Did I have an impact on someone else? _____

Was it easier or tougher than expected to complete your service hours? _____

Did I achieve my academic goals and potential? _____

On a snowy day, General Robert E. Lee took his eight year old son, Custis, out for a walk. Wearied by the high drifts, Custis began to fall behind his father.

After a few minutes Lee looked back and found that his boy was behind him, imitating his every move and walking in the tracks the father had made in the snow.

“When I saw this,” Lee told one of his friends long afterwards, “I said to myself, it behooves me to walk very straight when this fellow is already following in my tracks.”

Douglas Southall Freeman, *R.E. Lee vol. I* (New York: Macmillan, 1934), 178

QUEST FOR LEADERSHIP

Completed Expectations

Please check off each expectation as you fulfill it and complete the corresponding information. Once you have completed all expectations, please sign this form and show it to your phase commander. He will send notification to the National Administrative Office so that your completion of this phase may be noted.

INDIVIDUAL

- Maintain a semester or quarterly GPA of at least 2.5.
List your GPA from the most recent semester or quarter: _____
- Complete a leadership style self-assessment.
- Address a relevant social issue.
List issue addressed and manner for addressing it: _____
- Attend a guest speaker on a leadership or social issue.
Name of speaker, date, and topic: _____
- Read one book on leadership
Name of the book and author, date completed: _____

KAPPA ALPHA ORDER

- Attend 80 percent of all chapter functions.
- Assist in organizing one project benefiting MDA.
List name of project: _____
- Assist in the organization of one experiential learning activity for your chapter.
- Attend province council if you have not already done so.
Where and when did you attend province council. _____
- Present a short synopsis of your book.
- Participate in three scenario based learning discussion groups
What three topics were discussed: _____
- Continue to hold a leadership position within KA.
List the position you hold within KA: _____



QUEST FOR LEADERSHIP

Completed Expectations

COMMUNITY

- Complete 33 hours of community service.
What charity or organization did you assist? _____
- Participate in a weekend long leadership retreat or leadership institute.
List the retreat or institute you participated in: _____
- Hold a leadership position in a university organization, outside of KA.
List the organization and position you hold: _____
- Attend an IFC or SGA meeting.

I certify that the above information is accurate and complete.

Crusader's Signature

Phase Commander's Signature

Date

Date

*Ask not what your country can
do for you - ask what you can do
for your country*

John F. Kennedy



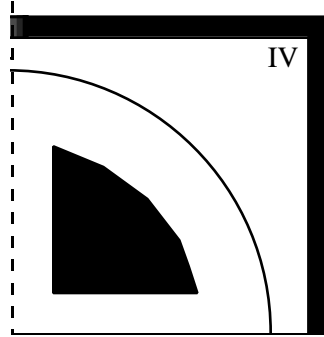

PHASE IV

The Journey
Beyond



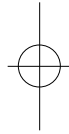
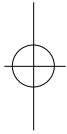

*It takes a long time to bring
excellence to maturity.*

Publius Syrus

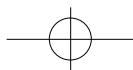

THE JOURNEY BE YOND

SUMMARY

This final phase in your crusade for excellence has been designated, *The Journey Beyond*. Intended for completion during your final year in college, this phase has been designated as a time for you to acquire the necessary tools for your crusade into the world beyond your college campus. Focus will be given to career enhancing activities, service in the community, and the responsibility of KA membership after graduation. You will be asked to address career-related topics such as resume building, interview skills, and dressing for success. Businessmen will be brought in to supplement your research. Additionally, local alumni will speak to you on the importance of your involvement in KA after graduation. Additionally, you will continue your involvement in the community through participation in 33 hours of community service. All of these activities will help prepare you for your journey beyond graduation.

OBJECTIVE

To develop a resume or complete a graduate school application

To learn proper interview skills

To research careers of interest to you

To understand the importance of Kappa Alpha involvement as an alumnus

To participate in service learning by participating in community service

To gain an appreciation for community governance

To evaluate your college experience from an un-biased perceptive

THE MEASURE OF SUCCESS

“To laugh often and much, to win the respect of intelligent people and affection of children; to earn the appreciation of honest critics and endure the betrayal of false friends; to appreciate beauty, to find the best in others; to leave the world a bit better, whether by a healthy child, a garden patch or a redeemed social condition; to know even one life has breathed easier because you have lived. This to have succeeded.”

Ralph Waldo Emerson

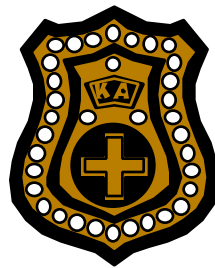



THE CONTINUING ROAD

Yes, I am a Kappa Alpha.

Even though I have not been an active member of Beta Epsilon chapter for some forty years, that phrase means more to me now than it did when I pledged at the University of Delaware. Several years ago, when I was being inducted into the university's Wall of Fame, I remember thinking that it was my Kappa Alpha experience that was responsible for this particular honor. I soon realized that it was not only responsible for this, but also much more.

Each step, in my life as a Kappa Alpha, has afforded me the opportunity for growth; both personal and professional. Most of the time we are unaware of what I call the Kappa Alpha Process. Quite possibly the process is more effective if we do not try to analyze it. However, we are in it and we must go with the flow as they say. Only later in life do we really begin to understand the fullness of our undergraduate KA experience. Even then, we must stop and think about the entire process to appreciate what we have done, where we have been, what we have learned and how it has helped our past and present and how it will help our future.

During a lifetime, one is given what I call impressions and principles. If you are an adept student, you will learn that these impressions and principles make up the core of your being. My Kappa Alpha experience over these many years has given me both.

The impression left on me by the upperclassmen, while a pledge and later as an initiated brother, put in place a guidance system that remains with me today. In a very practical sense, no institution of higher education, no professional school, no three-day seminar, could have ever educated me as did my chapter experience. I lived it, I listened to it, I watched it, I practiced it, I was supported by it, I grew in it and I passed it on.

The Kappa Alpha experience gave me the opportunities for leadership which I most likely would never have experienced. From early on, as president of my pledge class to president of the chapter, I had a hands-on education in responsibility and leadership. I recall being interviewed as a sophomore by the chapter president. He asked me what my plans at college were and where I was going to serve. It was expected in those days that KAs would seek leadership positions all over the campus. You were expected because you were special in you were a Kappa Alpha.

Through this nudging by upperclassmen we were put on a road and given a direction and the expectations were very high. We were expected to sharpen our social skills and practiced good time management all the while marching towards graduation with a respectable grade point average.

Most significant in my own life, after my bachelor's degree, has been the influence individual brothers have had on my path. Fortunately I have had many Kappa Alphas who have served as role models and mentors. Had those brothers not been there for me, my life certainly would have been less full.

This road then, as many realize, does not end with graduation. It continues throughout our lives. It is a road that Lee set the course for, that Ammen paved and that we accepted at our altar. How far we travel down it, and what we notice and experience along the way is up to us. Will we make the most of the treasures that we have been given?

Dr. William R. Baldt (Beta Epsilon '54) Kappa Alpha Order Trustee

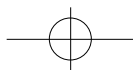



THE JOURNEY BEYOND

EXPECTATIONS

The last phase of The Crusade has been designed to allow you to gain the skills necessary to begin your career beyond college. The following expectations have been developed to allow you to gain those tools necessary for your journey beyond graduation. Once again, there are expectations that must be completed individually, within Kappa Alpha Order, and within your campus and community. These expectations must be met within this phase. They may not be completed prior to your admittance into this phase.

INDIVIDUAL

- Maintain a semester or quarterly GPA of at least 2.5.
- Develop a resume, or complete a model graduate/law school application, or write a short article on yourself outlining your accomplishments during college.
- Attend two guest speakers. One speaker should address a career development topic such as dressing for success, interview skills or a career of interest to you. The second speaker should address the importance of charitable giving.
- Address career-related topics within your phase groups.

KAPPA ALPHA ORDER

- Attend 80 percent of all chapter functions.
- Attend an alumni presentation - *KA for Life* - the importance of involvement after graduation.
- Participate in a career related scenario based learning discussion within your phase group
- Continue to hold a leadership role within KA.

COMMUNITY

- Participate in 33 hours of community service outside of KA.
- Remain active in a university organization outside of KA.
- Attend a city council meeting or an open session of court.
- Register to vote.

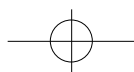



THE JOURNEY BE YOND

Expectations, Objectives, Plans

To help you successfully achieve the expectations of Phase 3 and your own personal goals you must first have a blueprint. The following pages are designed to help you create that “blueprint”. The first step in this process is to identify and jot down any personal goals that you may have. Secondly, record a realistic completion date. From this date backward plan and make notes of the specifics of how you plan to complete your objective. Additionally, note any major accomplishments or dates that need to happen in the notes section of your handbook.

REMEMBER - Goals are: Specific, Measurable, Action-Oriented, Realistic, and Timely

PERSONAL GOAL SETTING

Personal Goal 1:

Goal: _____

Target Date for Completion: _____

Specific Actions: _____

Personal Goal 2:

Goal: _____

Target Date for Completion: _____

Specific Actions: _____

Personal Goal 3:

Goal: _____

Target Date for Completion: _____

Specific Actions: _____

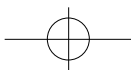



THE JOURNEY BE YOND
Individual Expectations

Expectation: Maintain at semester or quarterly GPA of at least 2.5.

Personal Goal (if different from expectation): _____

Target Date for Completion: _____

Specific Actions: _____

Expectation: Develop a resume, or complete a model graduate/law school application, or write a short article on yourself outlining your accomplishments during college.

Personal Goal (if different from expectation): _____

Target Date for Completion: _____

Specific Actions: _____

Expectation: Attend two guest speakers, topics should address career-related issues and charitable giving.

Personal Goal (if different from expectation): _____

Target Date for Completion: _____

Specific Actions: _____

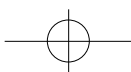



THE JOURNEY BE YOND

Individual Expectations

Expectation: Address career-related topics within your phase groups.

Personal Goal (if different from expectation): _____

Target Date for Completion: _____

Specific Actions: _____

You will soon be a knight, my son. . . If you encounter, near or far, a lady in need of help, or any damsel in distress, be ready to aid her if she asks you to, for all honour lies in such deeds. When a man fails to honour ladies, his own honour must be dead.

Percival's mother to Percival as he leaves for the search for the Holy Grail. Gies, *The Knights in History*





THE JOURNEY BE YOND

Kappa Alpha Order Expectations

Expectation: Attend 80 percent of all chapter functions.

Personal Goal (if different from expectation): _____

Target Date for Completion: _____

Specific Actions: _____

Expectation: Attend an alumni presentation - *KA for Life*- the importance of involvement after graduation.

Personal Goal (if different from expectation): _____

Target Date for Completion: _____

Specific Actions: _____

Expectation: Continue to hold a leadership role within KA.

Personal Goal (if different from expectation): _____

Target Date for Completion: _____

Specific Actions: _____





THE JOURNEY BE YOND

Kappa Alpha Order Expectations

Expectation: Participate in a career related scenario based learning discussion within your phase group.

Personal Goal (if different from expectation): _____

Target Date for Completion: _____

Specific Actions: _____

*What then is chivalry? So strong a thing,
 and of such hardihood, and so costly in the
 learning, that a wicked man or low dare
 not undertake it... Who, so would enjoy
 high honor must suitably display that he
 has well been schooled to such arts.*

William Marshall

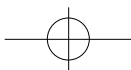



THE JOURNEY BE YOND

Expectations within the Campus and Community

Expectation: Complete 33 hours of community service before completing Phase 4.

Personal Goal (if different from expectation): _____

Target Date for Completion: _____

Specific Actions: _____

Expectation: Remain active in a university organization outside of KA.

Personal Goal (if different from expectation): _____

Target Date for Completion: _____

Specific Actions: _____

Expectation: Attend a city council meeting or an open session of court.

Personal Goal (if different from expectation): _____

Target Date for Completion: _____

Specific Actions: _____

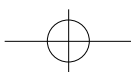



THE JOURNEY BE YOND

Expectations within the Campus and community

Expectation: Register to vote.

Personal Goal (if different from expectation): _____

Target Date for Completion: _____

Specific Actions: _____

*Do you see opportunity in every
difficulty, or difficulty in every
opportunity?*

Hippocrates



THE JOURNEY BE YOND

Resume & Interview Tips

Deciding on a career and landing your ideal job are two of the most important things you will do in life. It is probably the main reason you are in college and the goal you have been striving for throughout your college career. In essence, it is a means to an end. This section has been designed to help you in reaching that milestone. There are several things to perfect and consider along the way. Two major areas are the resume and the interview.

THE RESUME

The first step in planning for your career is to prepare a resume. There are several resources available to aid you in assembling your resume.

These include:

- Your campus career placement office
- The library
- Your peers
- The internet

You are now ready to write the resume. There are several guidelines to keep in mind when writing your resume. These include:

- Make it lively.
- Use action verbs and short sentences to grab the reader's interest.
- Be specific.
- Give facts and figures to support your accomplishments. Rather than saying you work well with other people, say, "I supervised and trained 10 employees and increased their productivity by 40 percent."
- Make it error free.
- Avoid negative impressions by checking and re-checking your resume for spelling and grammatical errors. It may also be helpful to have someone else proofread it for you.
- Keep it precise.
- The general rule is to try to limit your resume to one page. A recruiter does not have time to wade through an extensive autobiography.
- Make it look good.
- Have your resume professionally done and reproduced on good quality paper. Typically, white or ivory cardstock is recommended.
- Emphasize your accomplishments.
- Your resume is no place to be humble. Stress what you have achieved and the results. When listing your fraternity affiliation, always include offices held or awards received. A note of only "member" may cause a recruiter to wonder why you did not take a more active role. Also, assume the person



THE JOURNEY BE YOND

Resume & Interview Tips

- knows nothing about fraternities. Translate all Greek terminology. For instance, do not list “rush chairman,” list “member recruitment officer.”
- Don’t disregard volunteer work.

Congratulations! You have received a bite from your resume and have now scored an interview. There are some general rules of thumb regarding the interview itself.

These include:

- Appropriate personal appearance.
- Consider the nature of the position you are interviewing for and dress accordingly. If you are unsure, dress somewhat more formally than what you think is expected. A conservative suit is usually appropriate. Do not forget to pay attention to small details like polished shoes and neat hair.
- Show enthusiasm.
- Correlate your qualifications and experience with the requirements of the job.
- Make it clear to the interviewer why you are the right person for the job.
- Emphasize your ability to work well with others.
- Never speak negatively about your current boss.
- Use your answers as opportunities to give examples of how you have grown on the job.
- Ask closing questions, and as the interview ends, repeat the eye contact, smile and handshake.
- Always follow up with a Thank-you note.
- This should express your gratitude for the opportunity to learn more about the potential position. It is also your opportunity to briefly emphasize the positive aspects of the interview.

NOTE:

If asked about your fraternity membership during an interview, do not emphasize the social aspects, since most people are already familiar with that. Focus instead on leadership roles, community service, or the sense of teamwork you gained in accomplishing a particular chapter goal.

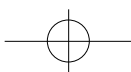



THE JOURNEY BE YOND

Resume & Interview Tips

Interview Checklist:

Research the company.
Prepare questions to ask.
Prepare for questions you may be asked.
Dress appropriately.
Learn directions to the interview location.
Plan to arrive about 5 minutes early.
Bring extra copies of your resume.
Bring work samples where appropriate.
Shake hands firmly.
Be relaxed.
Maintain eye contact.
Respond briskly and concisely.
Volunteer information only if it is positive and pertinent.
Relate your skills and experience.
Allow the interviewer to control the interview.
Watch for opportunities to sell your skills.
Be sure you understand the question before you answer.
Send a thank-you or follow-up letter.

Source: <http://www.flatley.com/check.htm>

Questions to Expect Include:

Tell us a little about yourself.
What qualifications do you possess that will help you in this job?
What are your greatest strengths and weaknesses?
What are your short and long-range objectives?
What is the one accomplishment of which you are most proud?
Why do you want to work for us?
What do you have to offer that other candidates do not?
What do you know about our company?

It is also important to plan in advance some questions of your own to ask.

Questions to Ask Include:

What are you looking for in a successful candidate?
What type of training is provided?
Where is the greatest room for improvement?
What is your long-term perspective of this position?

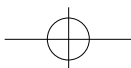



THE JOURNEY BE YOND

To Think About

Career Development

What resources did I utilize to aid me in developing my resume, or graduate school application? _____

What other activities did I participate in to help me reach my professional goals?

How will these activities aid me in beginning my career? _____

Have I prepared myself for graduation from college? _____

Alumni Involvement

How can I stay involved in KA once I graduate? _____

In what roles would I enjoy serving in as an alumnus? _____

Community Service

How did I complete my 33 hours of community service? _____

What organization did I volunteer for? _____

What did I learn from this experience about helping others? _____



THE JOURNEY BE YOND

Completed Expectations

Please check off each expectation as you fulfill it and complete the corresponding information. Once you have completed all expectations, please sign this form and show it to your phase commander. He will send notification to the National Administrative Office so that your completion of this phase may be noted.

INDIVIDUAL

- Maintain a semester or quarterly GPA of at least 2.25.
List your GPA from the most recent semester or quarter: _____
- Attend two guest speakers.
Name of career development speaker and date: _____
Name of charitable giving speaker and date: _____
- Address two career-related topics.
List issue addressed and manner of addressing it: _____

List issue addressed and manner of addressing it: _____

- Attend two presentations relevant to the Council of Honor or values and ethics.
Name of presenter, date, and topic: _____
Name of presenter, date, and topic: _____

KAPPA ALPHA ORDER

- Attend 80 percent of all chapter functions.
- Attend an alumni presentation - *KA for Life*.
Who was the presenter and what was the date of the presentation:

- Participate in a career-related scenario-based learning exercise within your phase group.
- Continue to hold a leadership position within KA.



THE JOURNEY BE YOND

Completed Expectations

COMMUNITY

- Participate in 80 hours of community service outside of KA.
List the organization you performed service for: _____
- Remain active in a university organization outside of KA.
List the organization you are a member of: _____
- Attend a City Council meeting or an open session of court.
- Register to vote.
Attach a copy or show your Voter ID Card to the phase commander.

I certify that the above information is accurate and complete.

Crusader's Signature

Phase Commander's Signature

Date

Date

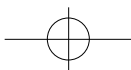
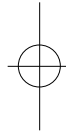
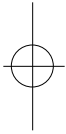

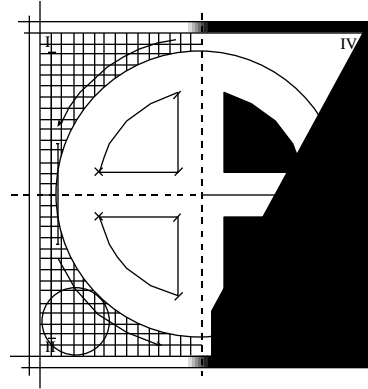

Appendix



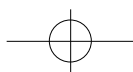
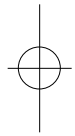
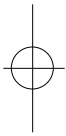

RESOURCES

The following books and websites are listed to help you on your crusade.

Phase I – *Voyage for Brotherhood*

Time Management -

- The Seven Habits of Highly Effective People: Restoring the Character Ethic by Stephen R. Covey, Copyright 1989, Simon & Schuster

Academics -

- Brains, Books and Brotherhood by Idris R. T aylor, A publication of Kappa Alpha Order.

Entertainment -

- The Whisper of the River by Ferrol Sams, copyright 1984, Peachtree Publishers Limited

Web Site -

- The Library of Congress - www.locweb.loc.gov - This site has the ability to search the entire library of Congress and it has an enormous online multimedia exhibit ranging from U.S. history to the performing arts.

Phase II – *Honor Bound*

Leadership -

- First Things First: to Live, to Love, to Learn, to Leave a Legacy by Stephen R. Covey, copyright 1994, Simon & Schuster
- Life's Little Instruction Book by H. Jackson Brown, Jr., copyright 1991, published by Rutledge Hill Press

History -

- History of Kappa Alpha Order, a publication of the Kappa Alpha Order, copyright 1994, Heritage Publishers
- The Book of the Order of Chivalry, translated by Robert Adams, copyright 1991, Sam Houston State University Press

Entertainment -

- Knights by Julek Heller & Deirdre Headon, copyright 1982, Bellew & Higton Publishers Ltd.

Web Sites -

- Kappa Alpha Order National Administrative Office - www.ka-order.org - This site will provide you with valuable information and can link you to other chapters around the country.
- National Interfraternity Council - www.nicindy.org - The NIC site is full of interesting materials and information on chapter operations and interfraternal-

RESOURCES

Phase III - *Quest for Leadership*

Leadership -

- Robert E. Lee on Leadership by H.W. Crocker III, copyright 1999, Prima Publishing Forum
- Principle-Centered Leadership by Stephen R. Covey, copyright 1991, Summit Books
- The One-Minute Manager by Kenneth Blanchard, Ph.D. & Spencer Johnson, M.D., copyright 1982, William Morrow and Company, Inc.
- Change Through Effective Leadership by Kenneth Blanchard, Ph.D. & Robert H. Guest, copyright 1982, William Morrow and Company, Inc.

Entertainment -

- Lee-The Last Years by Charles Bracelen Flood, copyright 1981, Houghton Mifflin Company
- My American Journey by Colin L. Powell with Joseph E. Persico, copyright 1995, Random House

Web Site -

- Northern Light - www.northernlight.com - This is a powerful search engine that can help you find even the most elusive items.

Phase IV - *The Journey Beyond*

Career Development -

- The Resume Solution - How to Write (and Use) a Resume That Gets Results by David Swanson, copyright 1994, JIST Works, Inc.
- The Complete Guide for Occupational Exploration - Based on U.S. Department of Labor Information
- The Job Doctor by Philip Norris, Ed.D., copyright 1994, JIST Works, Inc.

Web Sites -

Career related sites:

- Monster.com - www.monster.com
- Careerbuilder - www.careerbuilder.com
- Job Options - www.joboptions.com

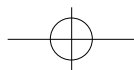
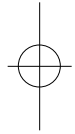
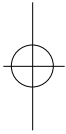
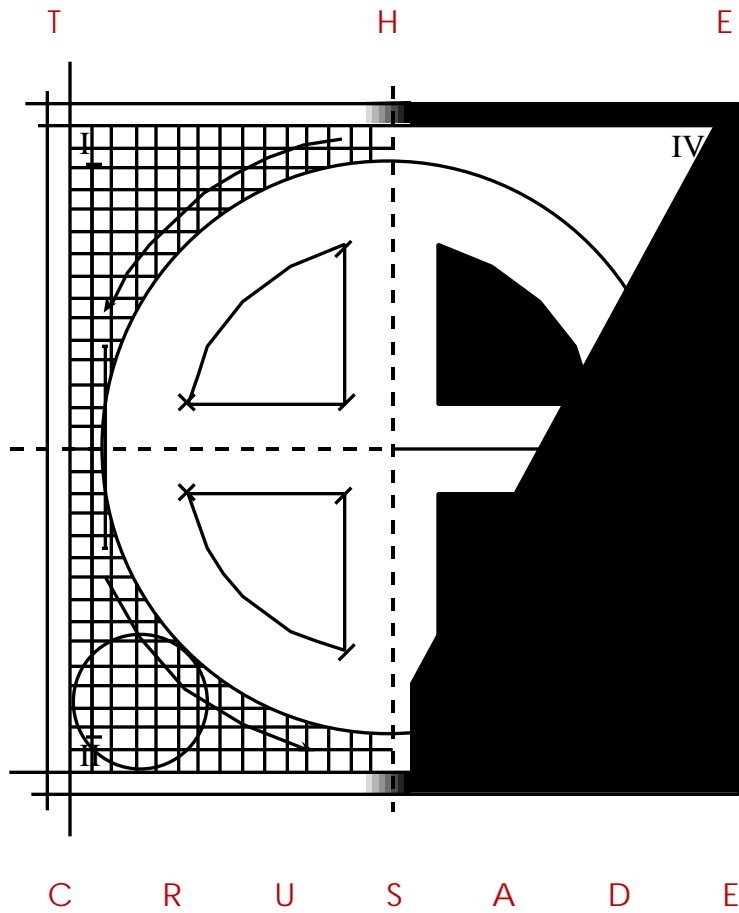

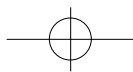
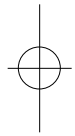
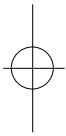

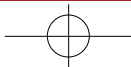
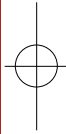
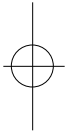
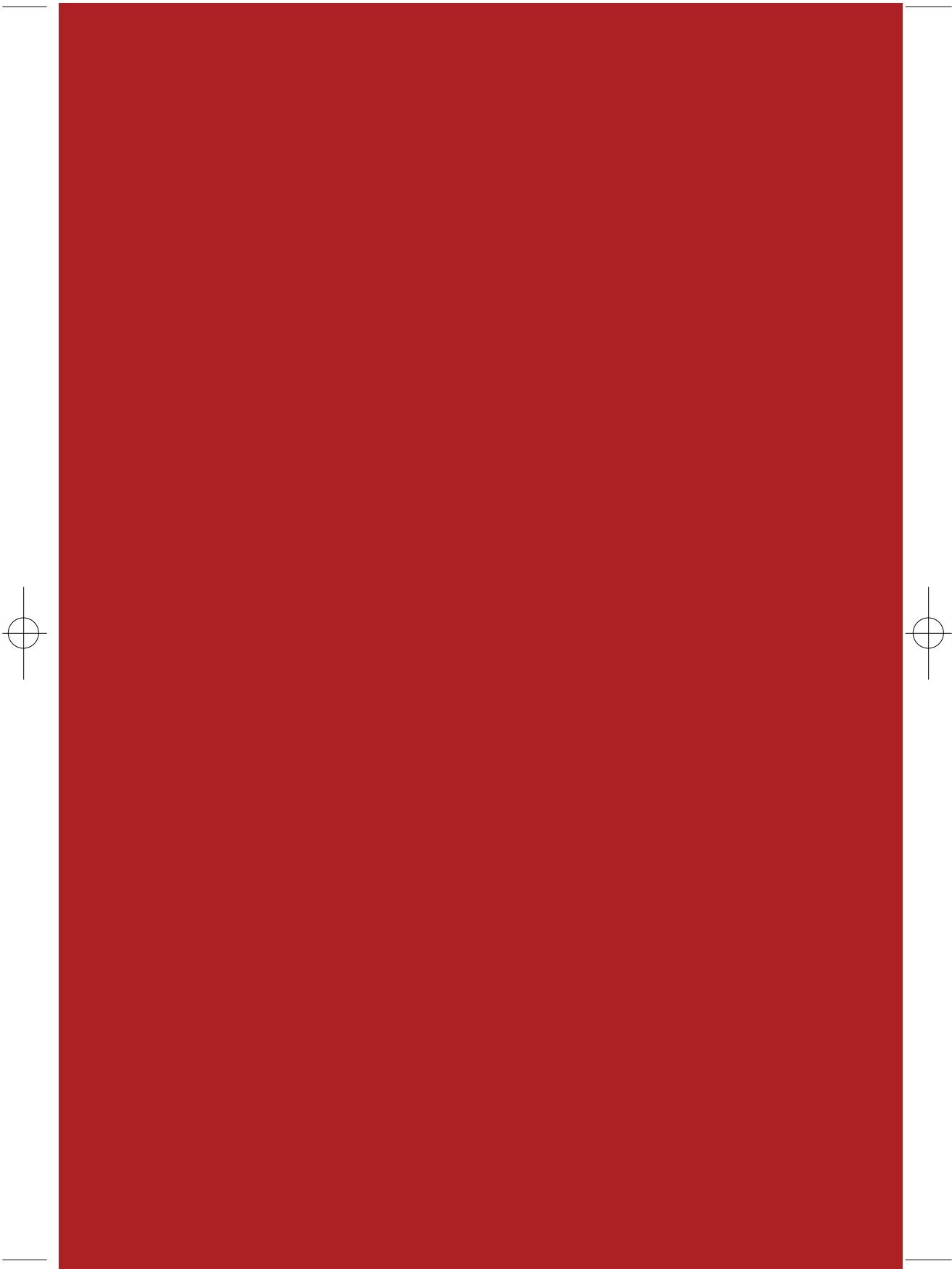

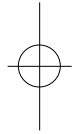
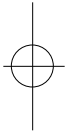

Kappa Alpha Order

P.O. Box 1865
Lexington, Virginia 24450
540.463.1865
fax: 540.463.2140
www.ka-order.org

